

Axle Housing

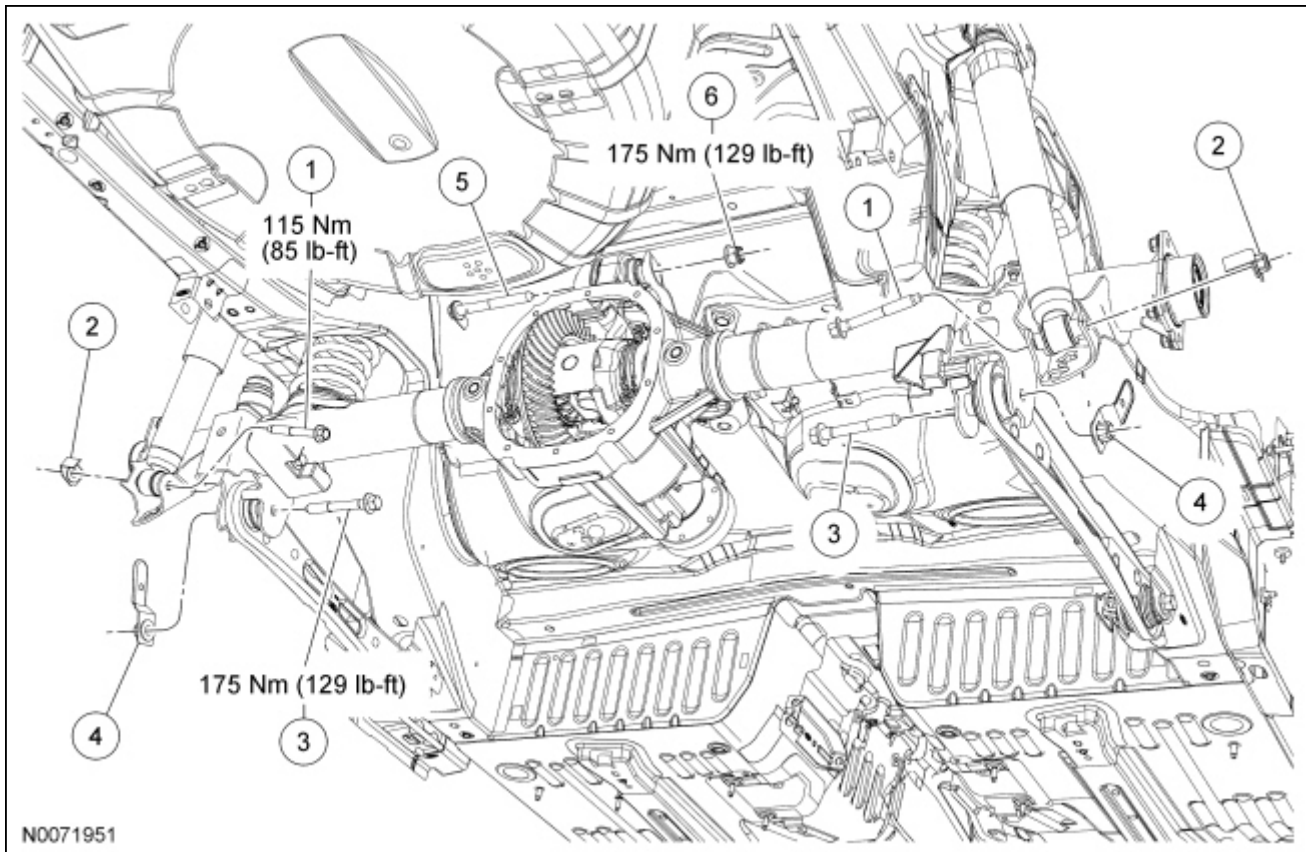

N0071951

Item	Part Number	Description
1	—	Shock absorber lower bolts (part of service kit 18008) (2 required)
2	—	Shock absorber lower flag nuts (part of service kit 18008) (2 required)
3	W704888	Lower arm bolts (2 required)
4	W704991	Lower arm nuts (2 required)
5	W710443	Upper arm bushing bolt
6	W520215	Upper arm bushing nut

Removal

All vehicles

NOTICE: Suspension fasteners are critical parts because they affect performance of vital components and systems and their failure may result in major service expense. New parts must be installed with the same part numbers or equivalent part, if replacement is necessary. Do not use a replacement part of lesser quality or substitute design. Torque values must be used as specified during reassembly to make sure of correct retention of these parts.

1. Mark the rear shock absorber relative to the protective sleeve with the vehicle in a static, level ground position

(curb height).

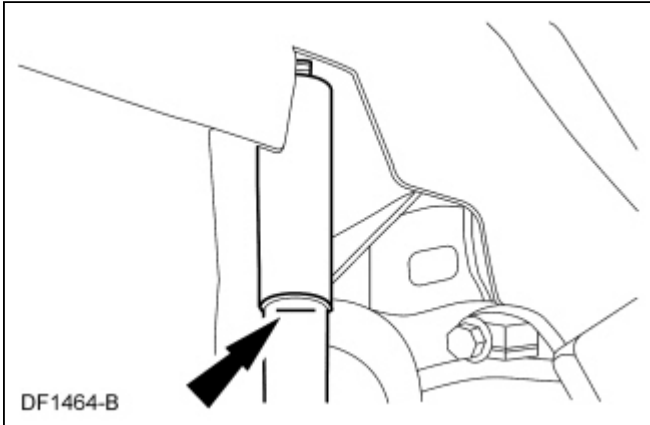

2. Remove the brake discs. For additional information, refer to [Section 206-04](#).
3. Remove the driveshaft. For additional information, refer to [Section 205-01](#).
4. Disconnect the 2 ABS wheel speed sensor electrical connectors.
5. Remove the stabilizer bar. For additional information, refer to [Section 204-02](#).
6. Remove the panhard rod. For additional information, refer to [Section 204-02](#).

Convertibles

7. Remove the rear support braces. For additional information, refer to [Section 502-00](#).

All vehicles

8. **NOTE:** Secure the differential housing to the transmission jack with a suitable strap.
Support the differential housing with a suitable transmission jack.
9. Remove and discard the 2 shock absorber lower nuts and bolts.
10. If equipped, disconnect the vent hose clip.
11. Remove and discard the upper arm bushing nut and bolt.

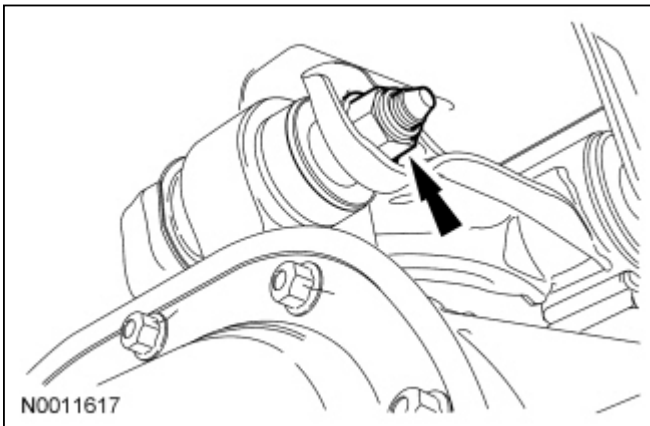

12. Lower the axle slightly and remove the springs.

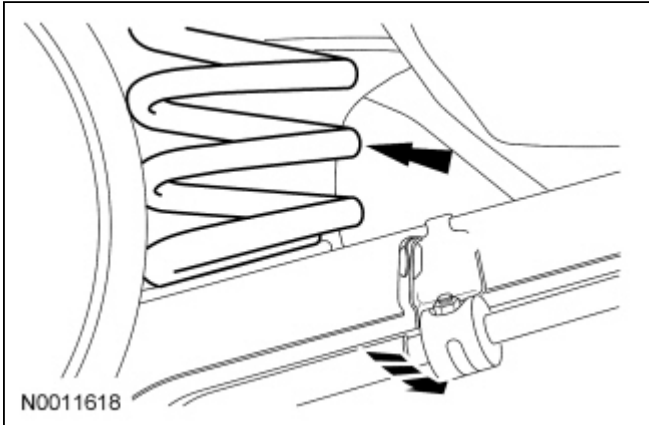

13. Remove and discard the 2 lower arm nuts and bolts.

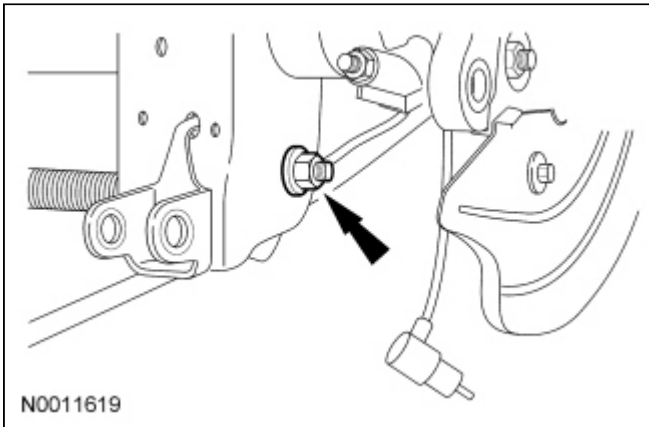

14. Disconnect the lower arms from the axle housing.

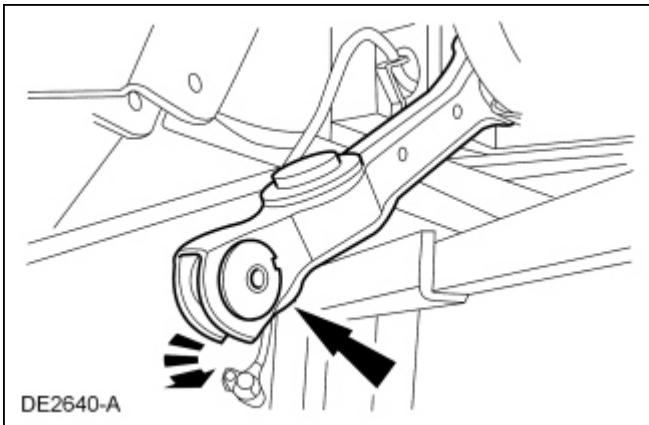

15. Lower the axle housing from the vehicle.

Installation

All vehicles

1. If installing a new rear axle, install a new upper arm bushing. For additional information, refer to [Section 204-02](#).

- Using a suitable transmission jack, position the axle housing in the vehicle and install the springs.

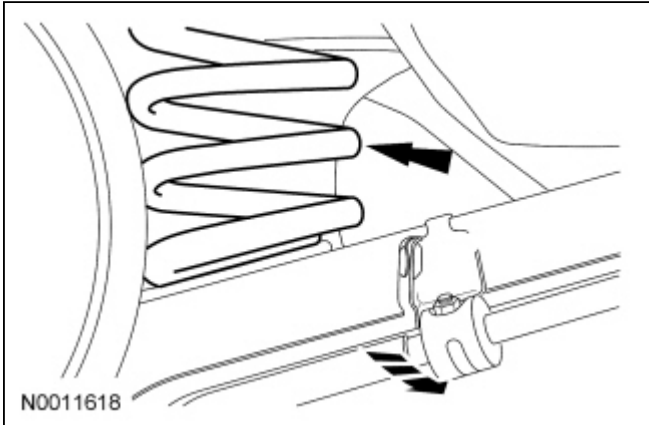

- NOTICE:** Tighten the new suspension fasteners while the suspension is at curb height or bushing damage and incorrect clamp load may occur.

Using 2 jackstands, raise the rear axle so the mark made on the rear shock absorber during removal lines up with the protective sleeve.

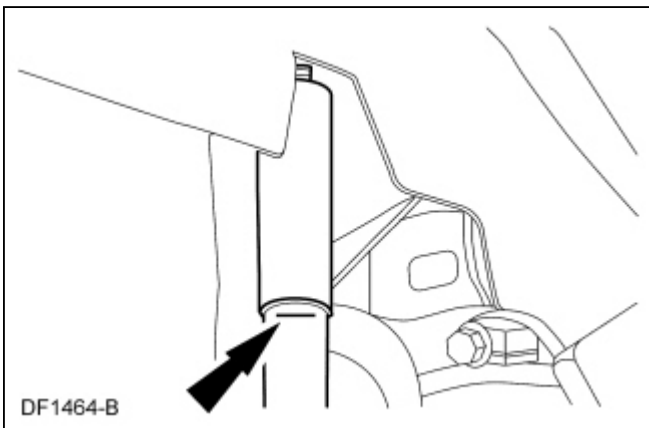

- Install a new upper arm bushing nut and bolt.
 - Tighten to 175 Nm (129 lb-ft).

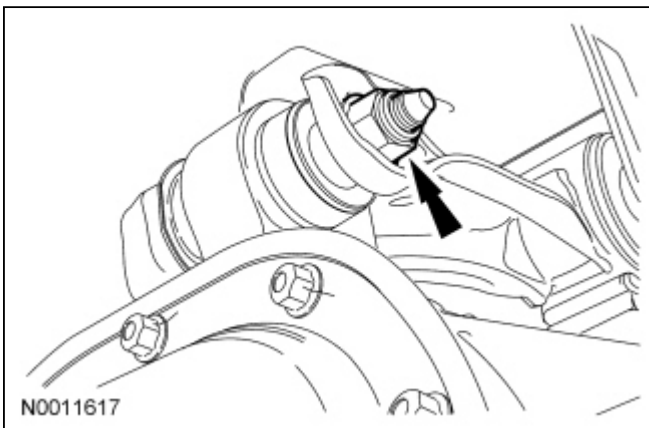

- If equipped, connect the vent hose clip.
- Position the lower arms to the axle housing.

7. Install 2 new lower arm nuts and bolts.
 - Tighten to 175 Nm (129 lb-ft).

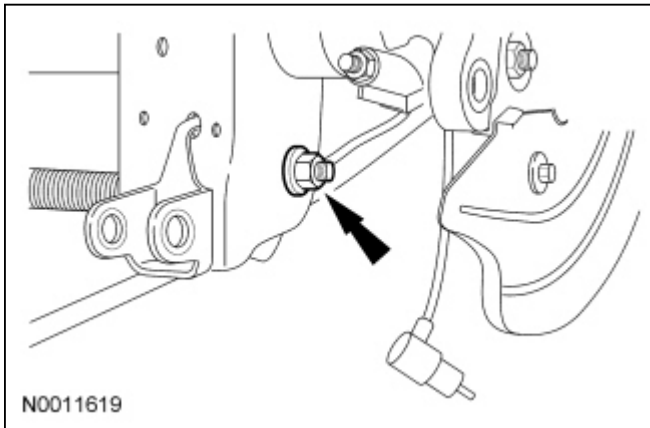

8. Install 2 new shock absorber bolts and flagnuts.
 - Tighten to 115 Nm (85 lb-ft).

Convertibles

9. Install the rear support braces. For additional information, refer to [Section 502-00](#).

All vehicles

10. Install the stabilizer bar. For additional information, refer to [Section 204-02](#).
 11. Install the panhard rod. For additional information, refer to [Section 204-02](#).
 12. Connect the 2 ABS wheel speed sensor electrical connectors.
 13. Install the driveshaft. For additional information, refer to [Section 205-01](#).
 14. Install the rear brake discs. For additional information, refer to [Section 206-04](#).
-

